

Calculating maximum density:

Square footage of site, less the area set aside for right-of-way and tracts of land dedicated for stormwater facilities;

÷ Maximum density from Table 17C.110-3;

= Maximum number of units allowed. If this formula results in a decimal fraction, the resulting maximum number of units allowed is rounded to the next whole number. Decimal fractions of .5 or greater are rounded up. Fractions less than .5 are rounded down.

Example density calculation for RTF zoned site:

5 acre site (217,800 sq. ft.) minus 43,560 square feet (20% set aside for right-of-way and tracts of land dedicated for stormwater facilities) =
174,240 sq. ft.

÷ 2,100 sq. ft. (Max. density for RTF zone)

= 82.9 units

Rounded up to 83 units allowed

Attached house minimum lot area = 1,600 sq. ft.

Example density calculation for RTF zoned site:

10,000 sq. ft. site

÷ 2,100 sq. ft. (Max. density for RTF zone)

= 4.76 units

Rounded up to 5 units allowed

Attached house minimum lot area = 1,600 sq. ft.

-could be developed into five 2,000 sq. ft. lots,

or four 1,600 sq. ft. lots and one 3,600 sq. ft. lot

Or?

RSF-C – Single Family, Detached (1-story)

RSF:

- 4350 sq. ft. min. lot area
- 40' min. lot width
- 5' side setback
- 25' rear setback

RSF-C:

- 3000 sq. ft. min. lot area
- 36' min. lot width
- 3' side setback
- 15' rear setback

Similarities:

- 15' front setback
- 0.5 FAR

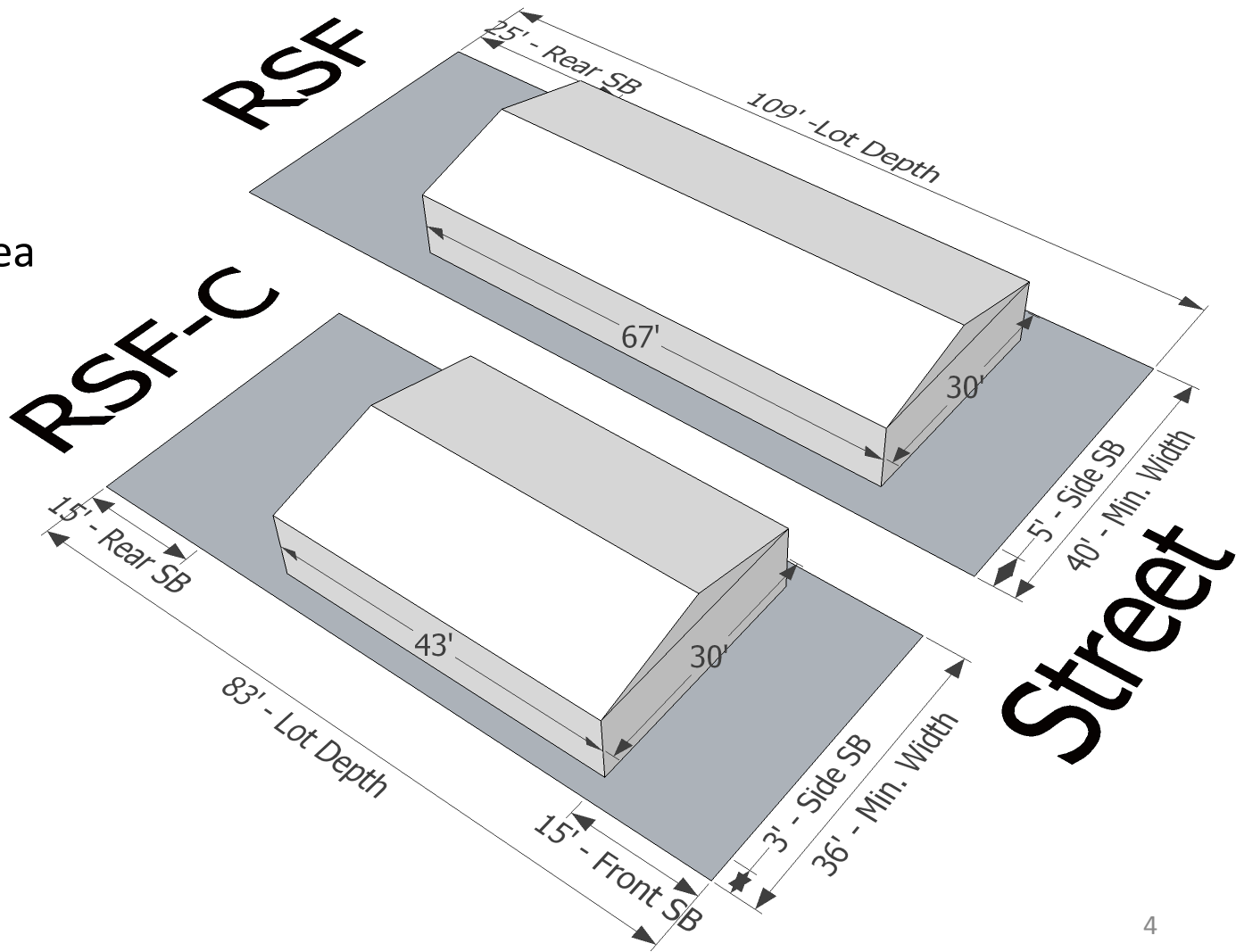

RSF-C – Single Family, Detached (2-story)

RSF:

- 4350 sq. ft. min. lot area
- 40' min. lot width
- 5' side setback
- 25' rear setback

RSF-C:

- 3000 sq. ft. min. lot area
- 36' min. lot width
- 3' side setback
- 15' rear setback

Similarities:

- 15' front setback
- 0.5 FAR

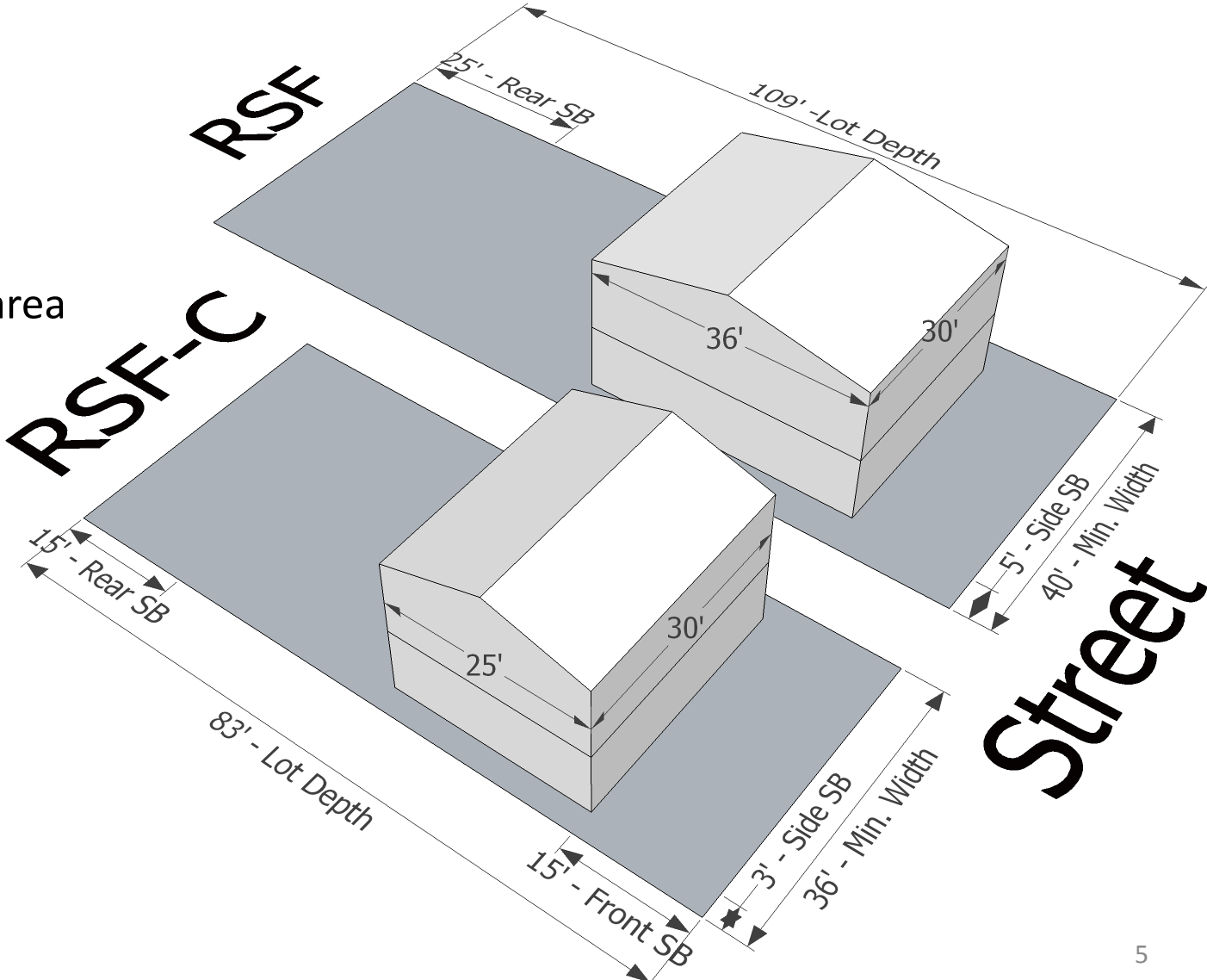

RSF-C – Single Family, Attached (1-story)

RSF:

- 4350 sq. ft. min. lot area
- 40' min. lot width
- 10' side setback
- 25' rear setback

RSF-C:

- 3000 sq. ft. min. lot area
- 36' min. lot width
- 6' side setback
- 15' rear setback

Similarities:

- 15' front setback
- 0.5 FAR

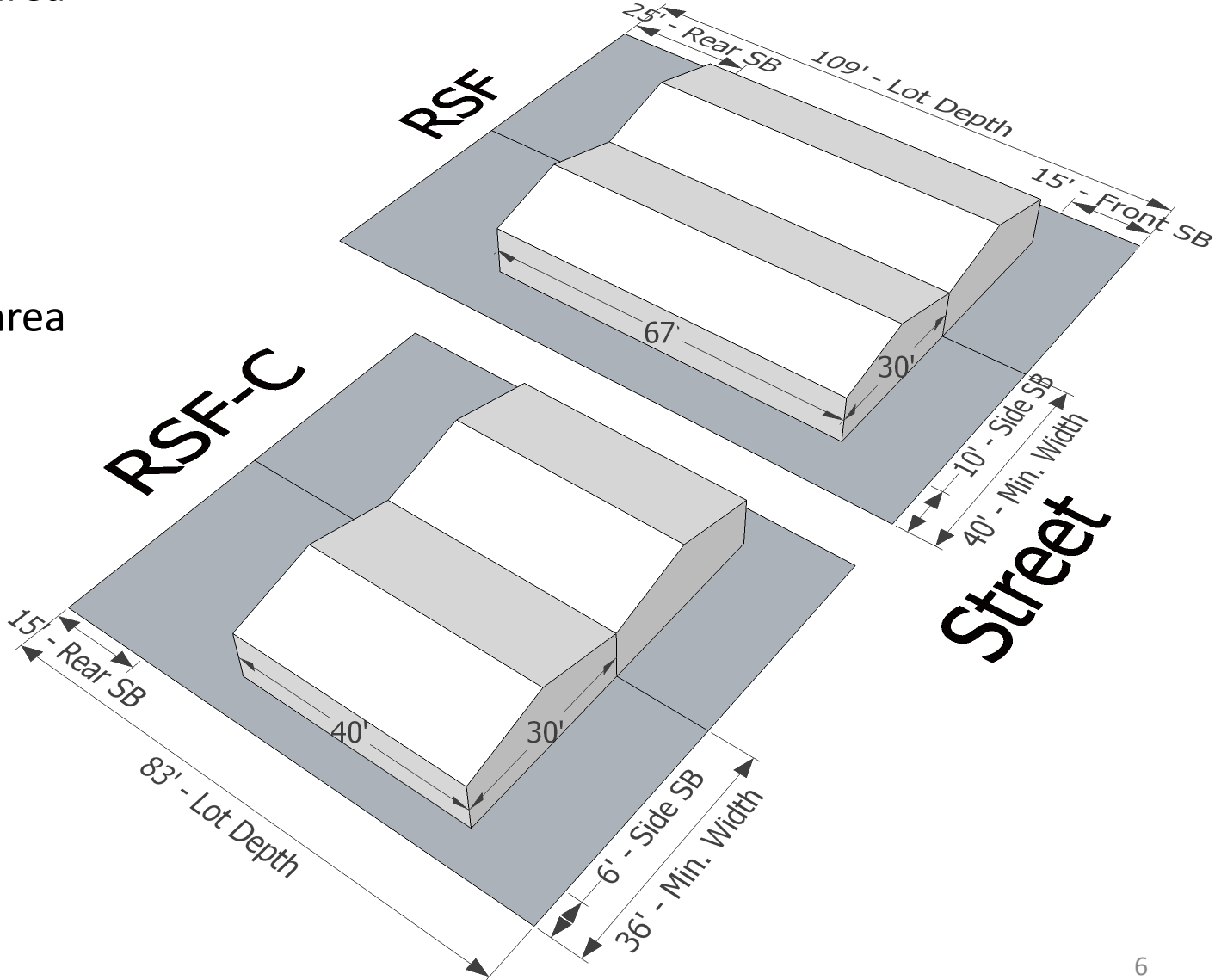

RSF-C – Single Family, Attached (2-story)

RSF:

- 4350 sq. ft. min. lot area
- 40' min. lot width
- 10' side setback

RSF-C:

- 3000 sq. ft. min. lot area
- 36' min. lot width
- 6' side setback
- 15' rear setback

Similarities:

- 15' Front Setback
- 0.5 FAR

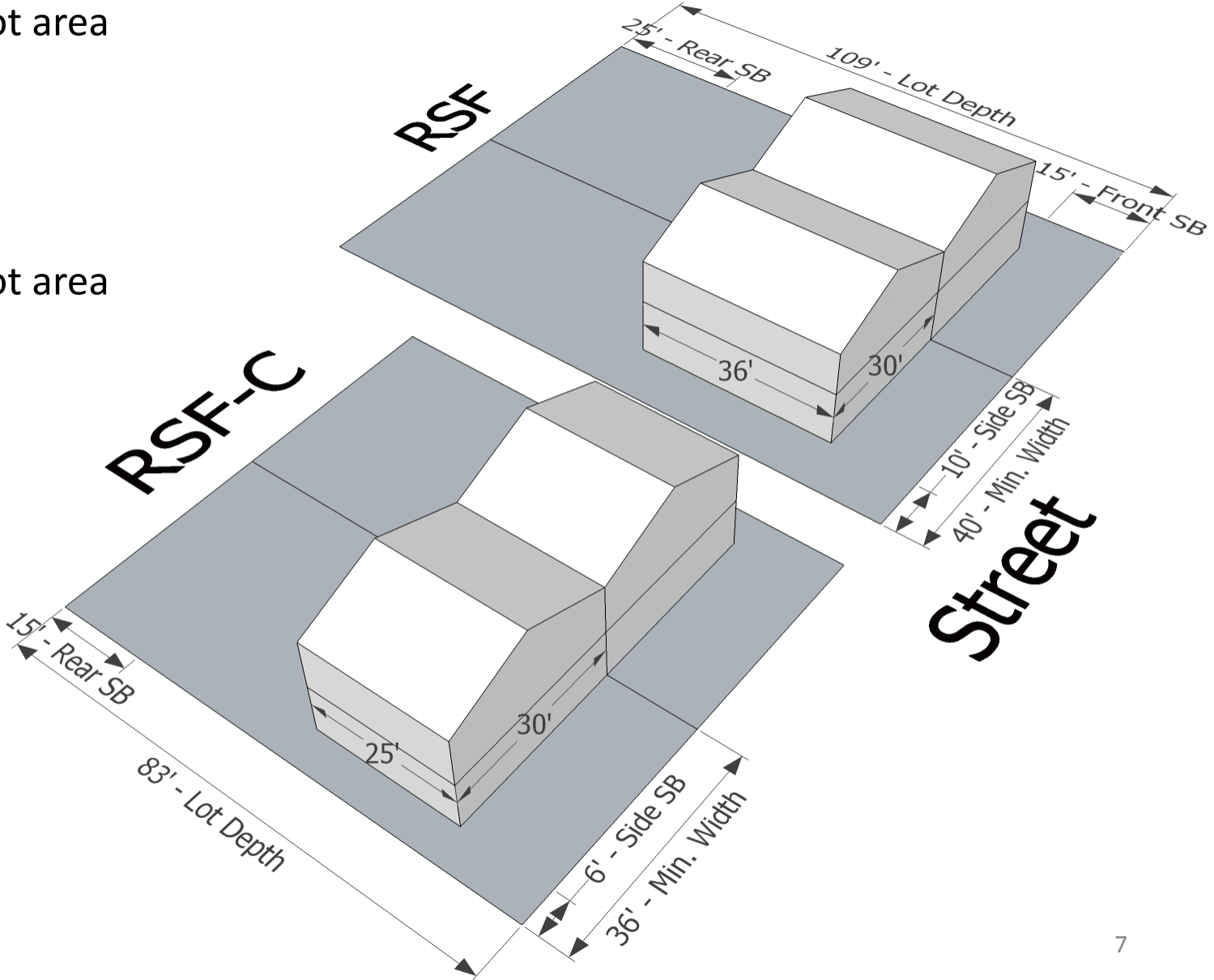

RTF – Single Family, Detached (1-story)

Existing:

- 4350 sq. ft. min. lot area
- 40' min. lot width
- 25' rear setback
- 5' side setback

Proposed:

- 1800 sq. ft. min. lot area
- 36' min. lot width
- 15' rear setback
- 3' side setback

Similarities:

- 15' front setback
- 0.5 FAR

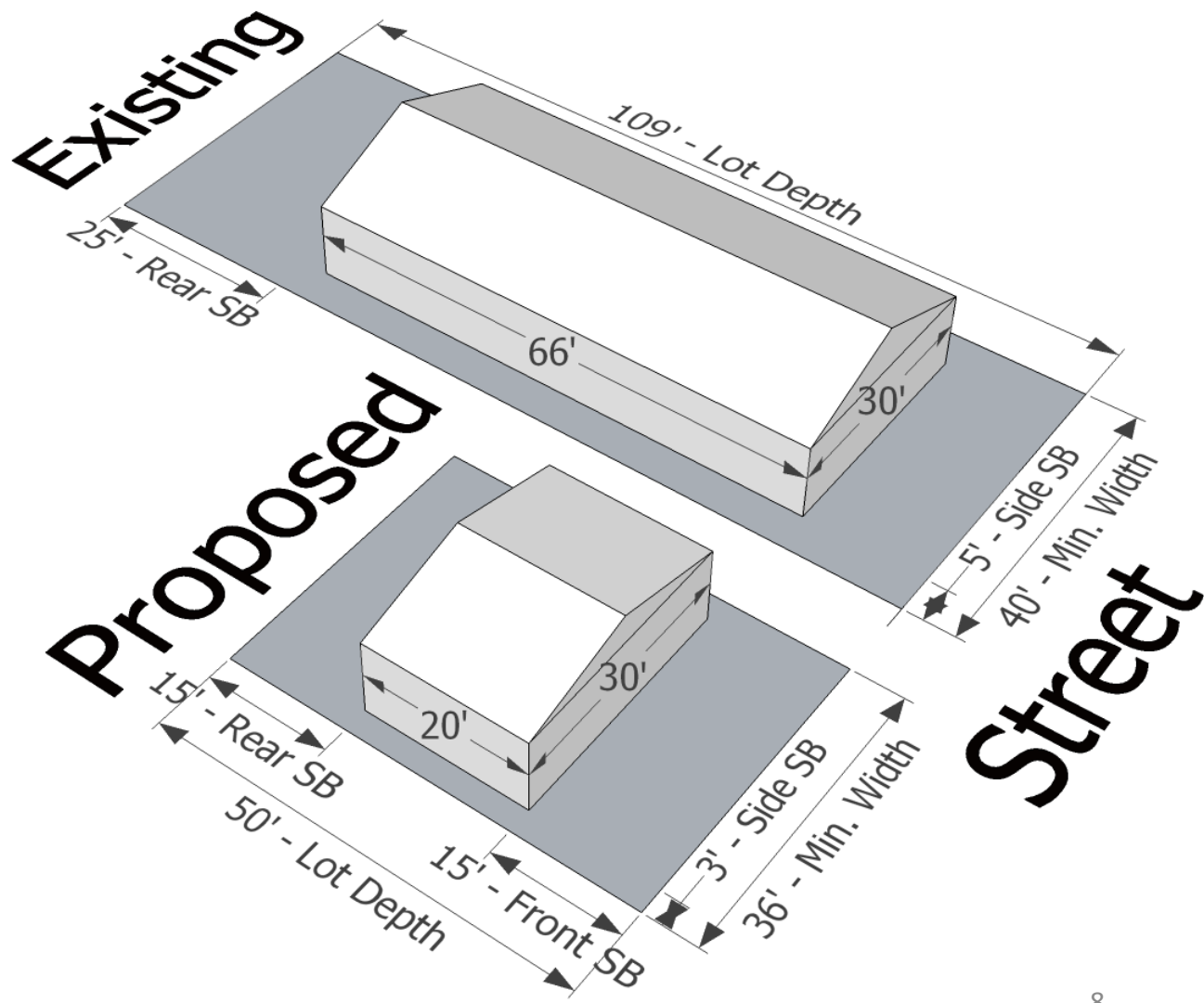

RTF – Single Family, Detached (2-story)

Existing:

- 4350 sq. ft. min. lot area
- 40' min. lot width
- 25' rear setback
- 5' side setback

Proposed:

- 1800 sq. ft. min. lot area
- 36' min. lot width
- 15' rear setback
- 3' side setback

Similarities:

- 15' front setback
- 0.5 FAR

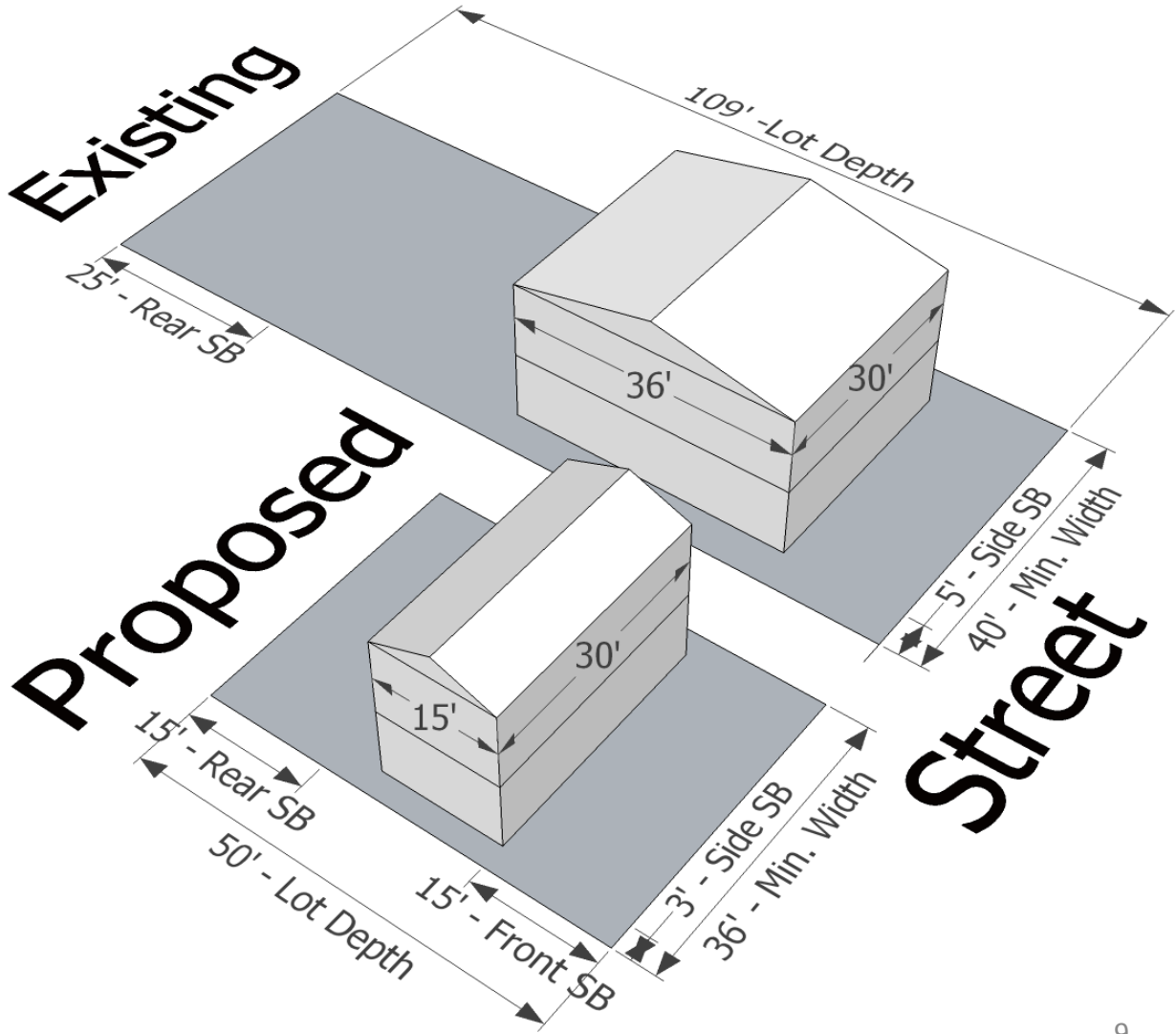

RTF – Single Family, Attached (1-story) (Small Lot)

Existing:

- 2500 sq. ft. min. lot area
- 25' min. lot width
- 25' rear setback

Proposed:

- 1600 sq. ft. min. lot area
- 16' min. lot width
- 15' rear setback

Similarities:

- 15' front setback
- 6' side setback
- 0.65 FAR

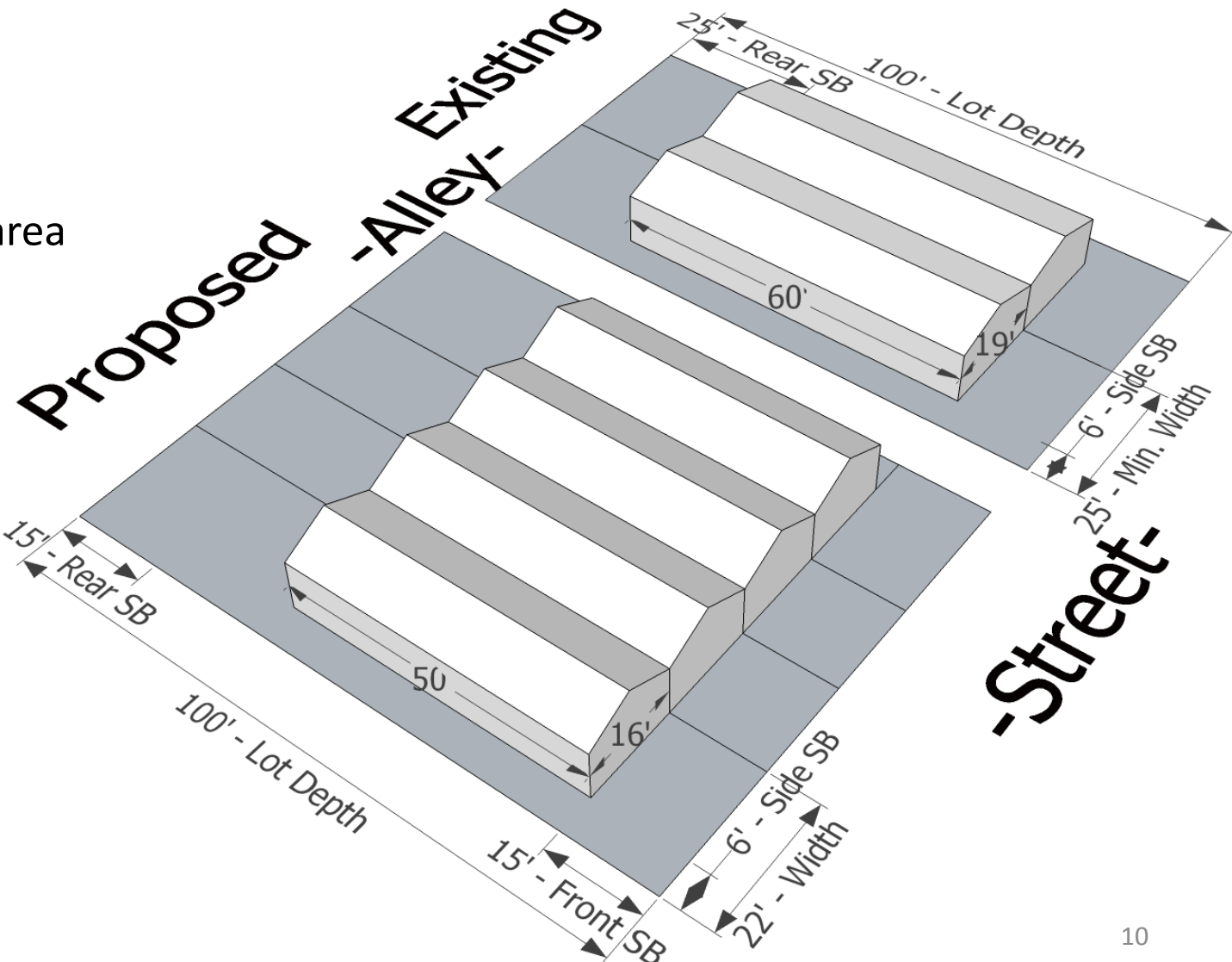

RTF – Single Family, Attached (2-story) (Small Lot)

Existing:

- 2500 sq. ft. min. lot area
- 25' min. lot width
- 25' rear setback

Proposed:

- 1600 sq. ft. min. lot area
- 16' min. lot width
- 15' rear setback

Similarities:

- 15' front setback
- 6' side setback
- 0.65 FAR

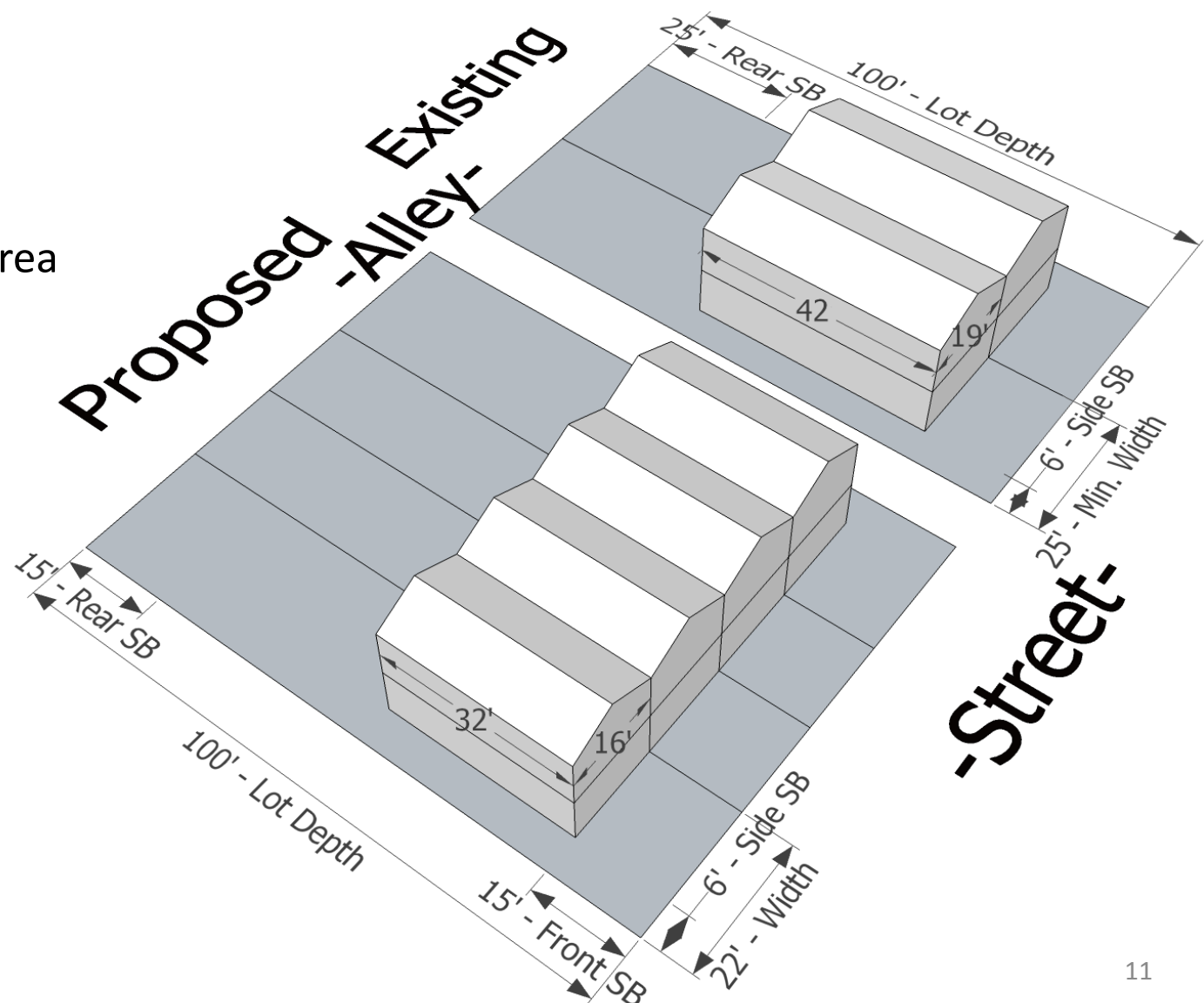

RTF – Duplex (1-story)

Existing:

- 4350 sq. ft. min. lot area
- 40' min. lot width
- 5' side setback
- 25' rear setback

Proposed:

- 4200 sq. ft. min. lot area
- 36' min. lot width
- 3' side setback
- 15' rear setback

Similarities:

- 15' front setback
- 5' street side lot line setback
- 0.5 FAR

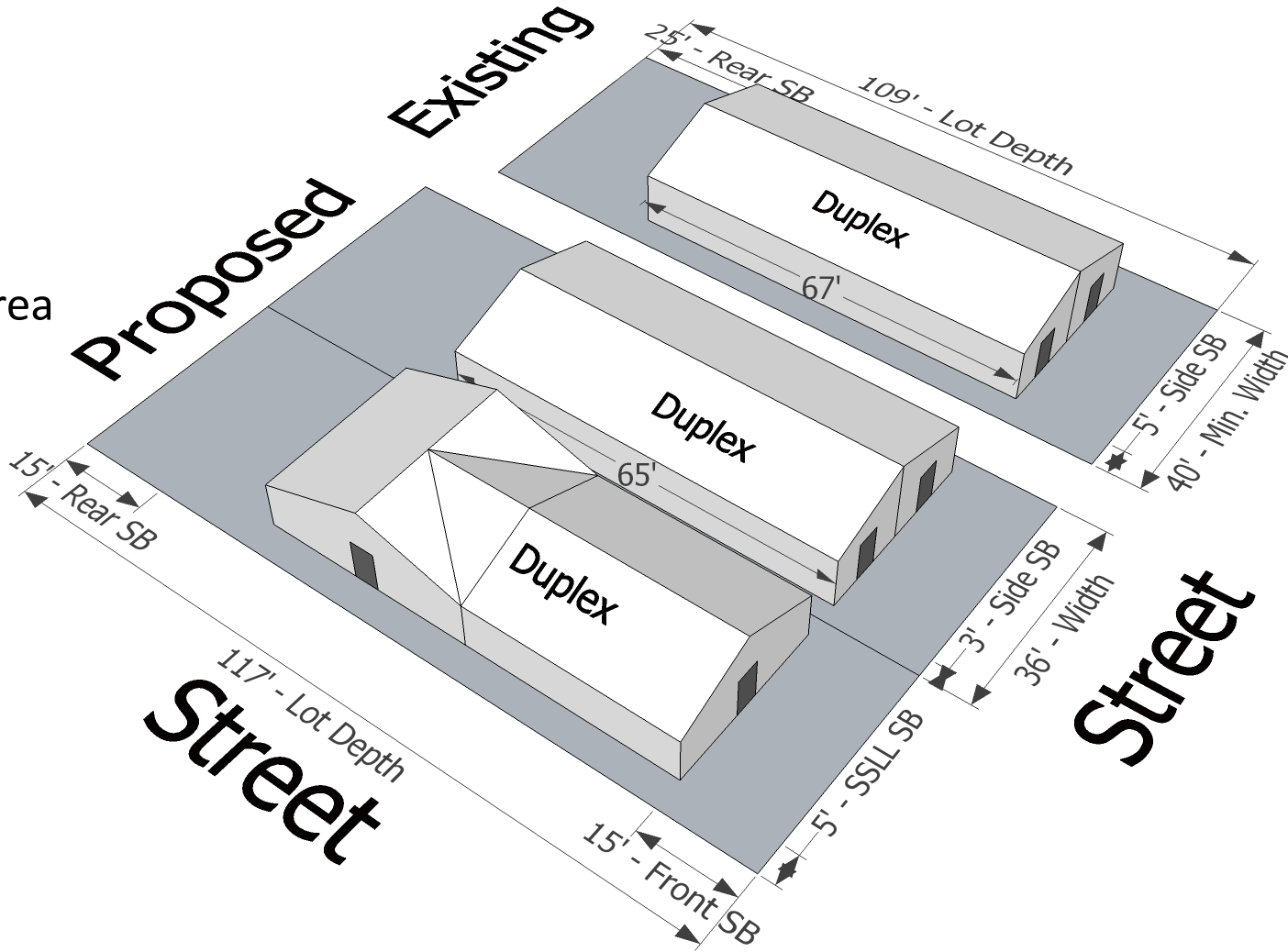

Note: On a corner lot duplexes, each unit must be oriented toward a street.

RTF – Duplex (2-story)

Existing:

- 4350 sq. ft. min. lot area
- 40' min. lot width
- 5' side setback
- 25' rear setback

Proposed:

- 4200 sq. ft. min. lot area
- 36' min. lot width
- 3' side setback
- 15' rear setback

Similarities:

- 15' front setback
- 5' street side lot line setback
- 0.5 FAR

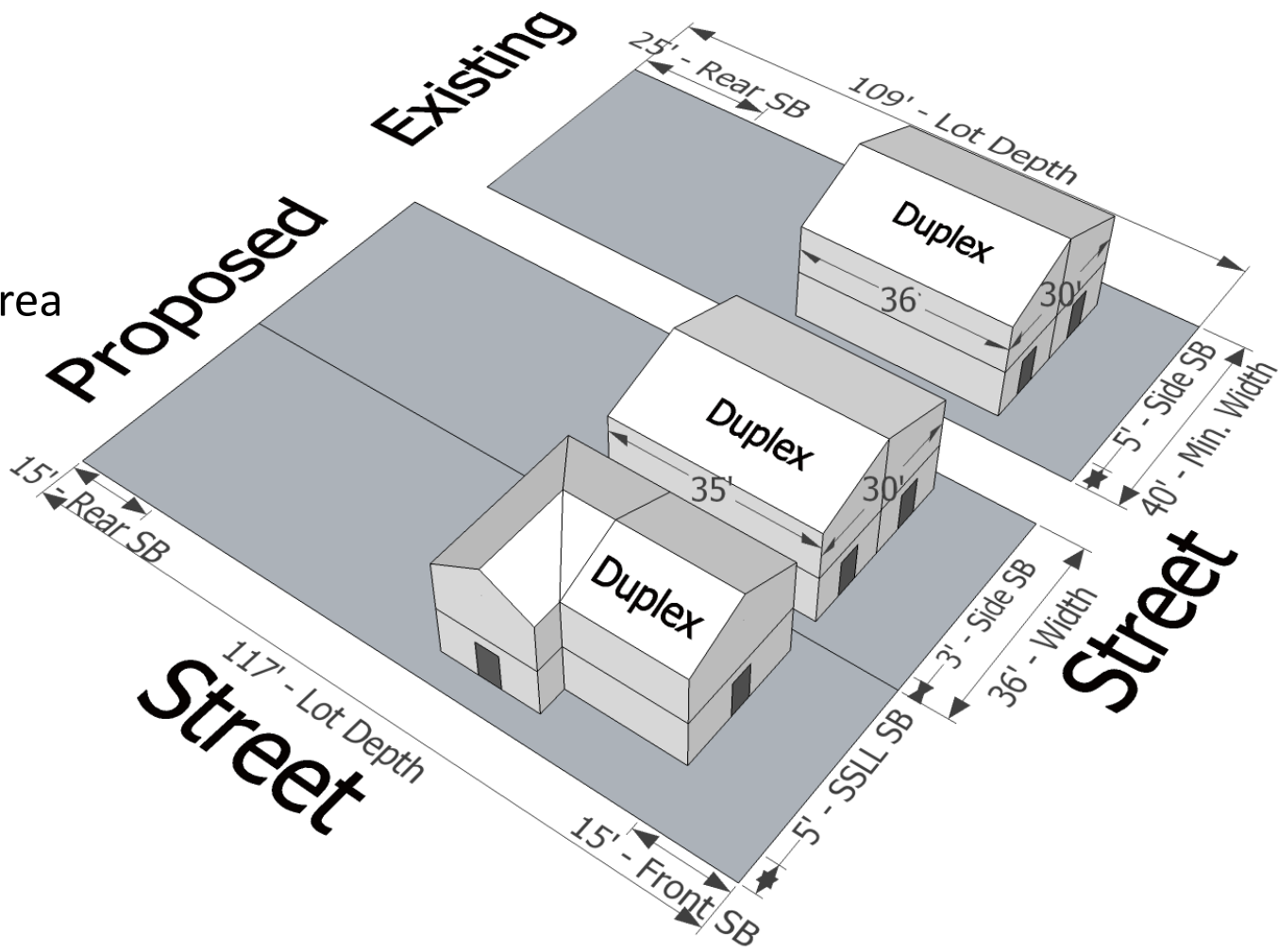

Note: On a corner lot duplexes, each unit must be oriented toward a street.

RMF – Single Family, Detached (1-story)

Existing:

2500 sq. ft. min. lot area

Proposed:

1800 sq. ft. min. lot area

Similarities:

- 25' min. lot width
- 15' front setback
- 10' rear setback
- 3' side setback
- No FAR limit

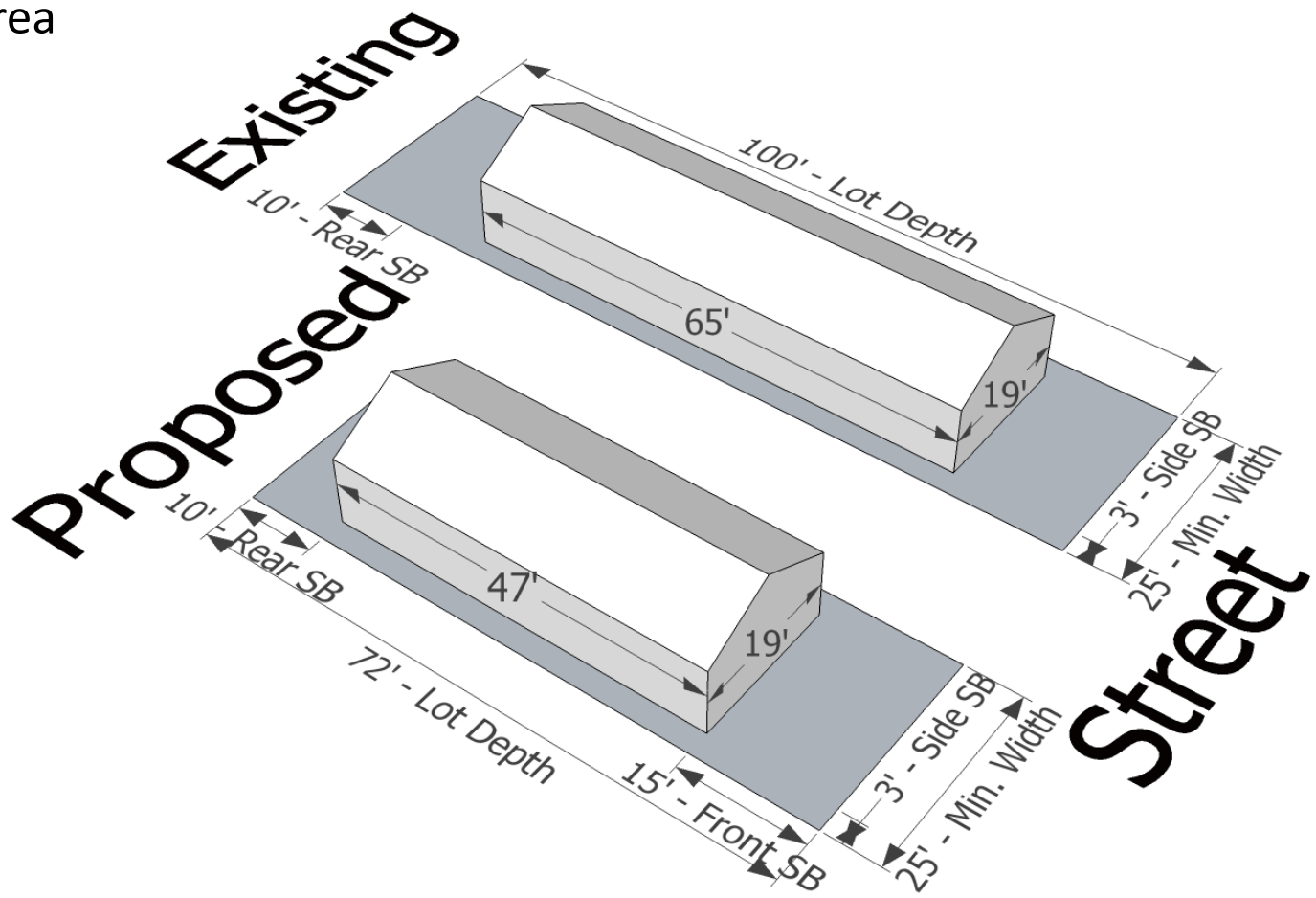

RMF – Single Family, Detached (2-story)

Existing:

2500 sq. ft. min. lot area

Proposed:

1800 sq. ft. min. lot area

Similarities:

- 25' min. lot width
- 15' front setback
- 10' rear setback
- 3' side setback
- No FAR limit

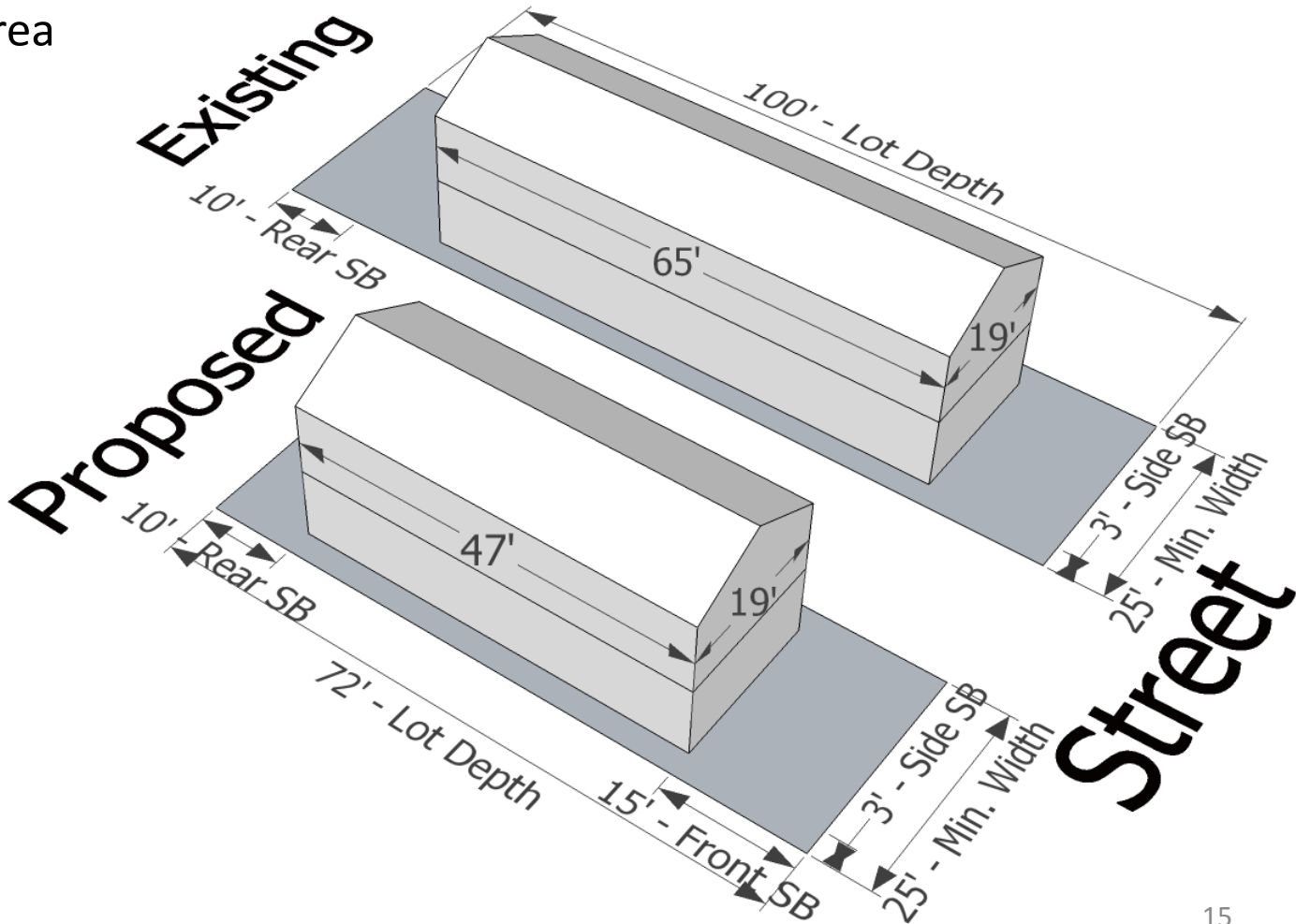

RMF – Duplex (1-story, realistic)

Existing:

- 2500 sq. ft. min. lot area
- 25' min. lot width

Proposed:

- 2900 sq. ft. min. lot area
- 25' min. lot width

Similarities:

- 15' front setback
- 10' rear setback
- 3' side setback
- No FAR limit

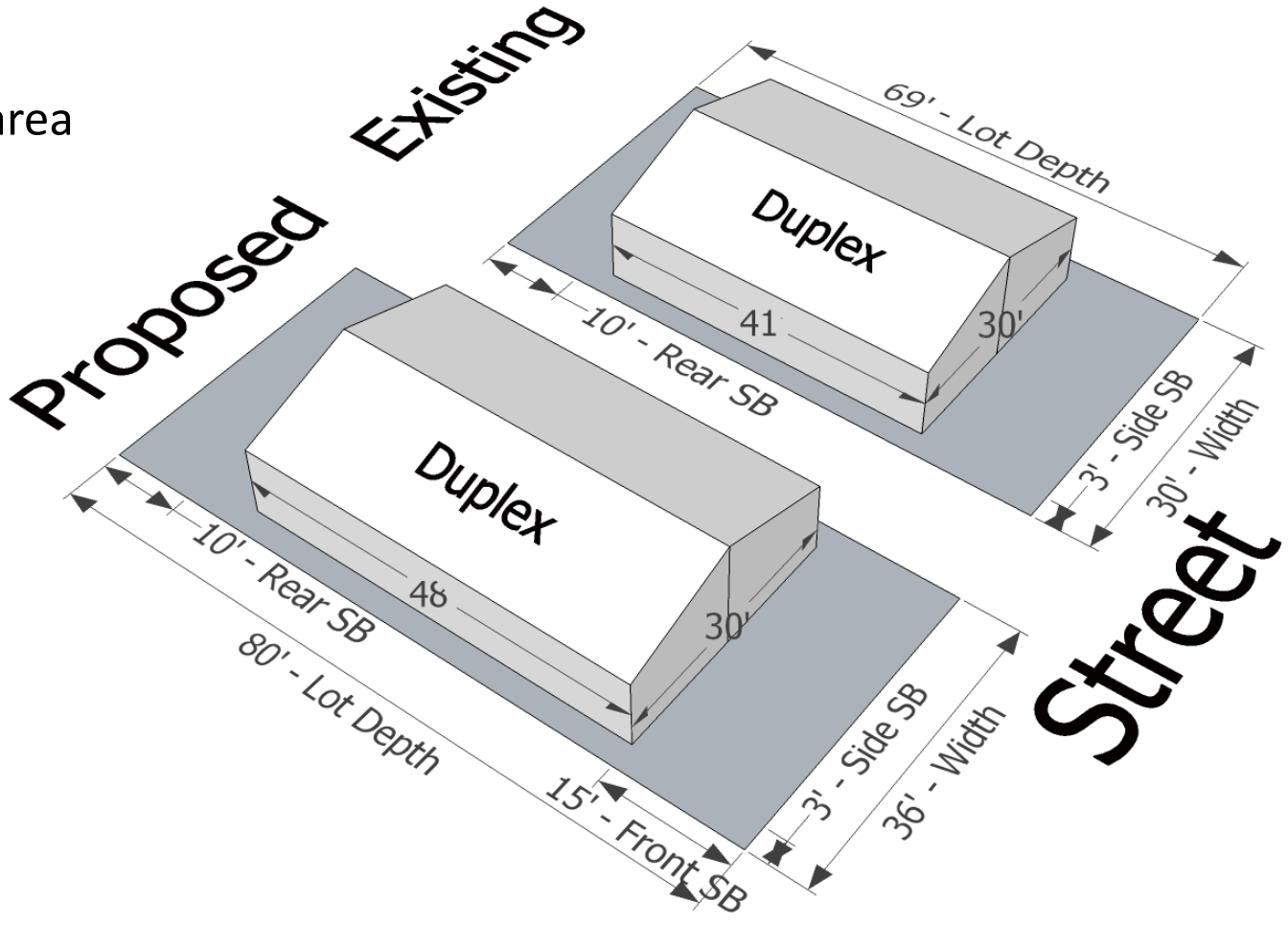

RMF – Duplex (2-story, realistic)

Existing:

- 2500 sq. ft. min. lot area
- 25' min. lot width

Proposed:

- 2900 sq. ft. min. lot area
- 25' min. lot width

Similarities:

- 15' front setback
- 10' rear setback
- 3' side setback
- No FAR limit

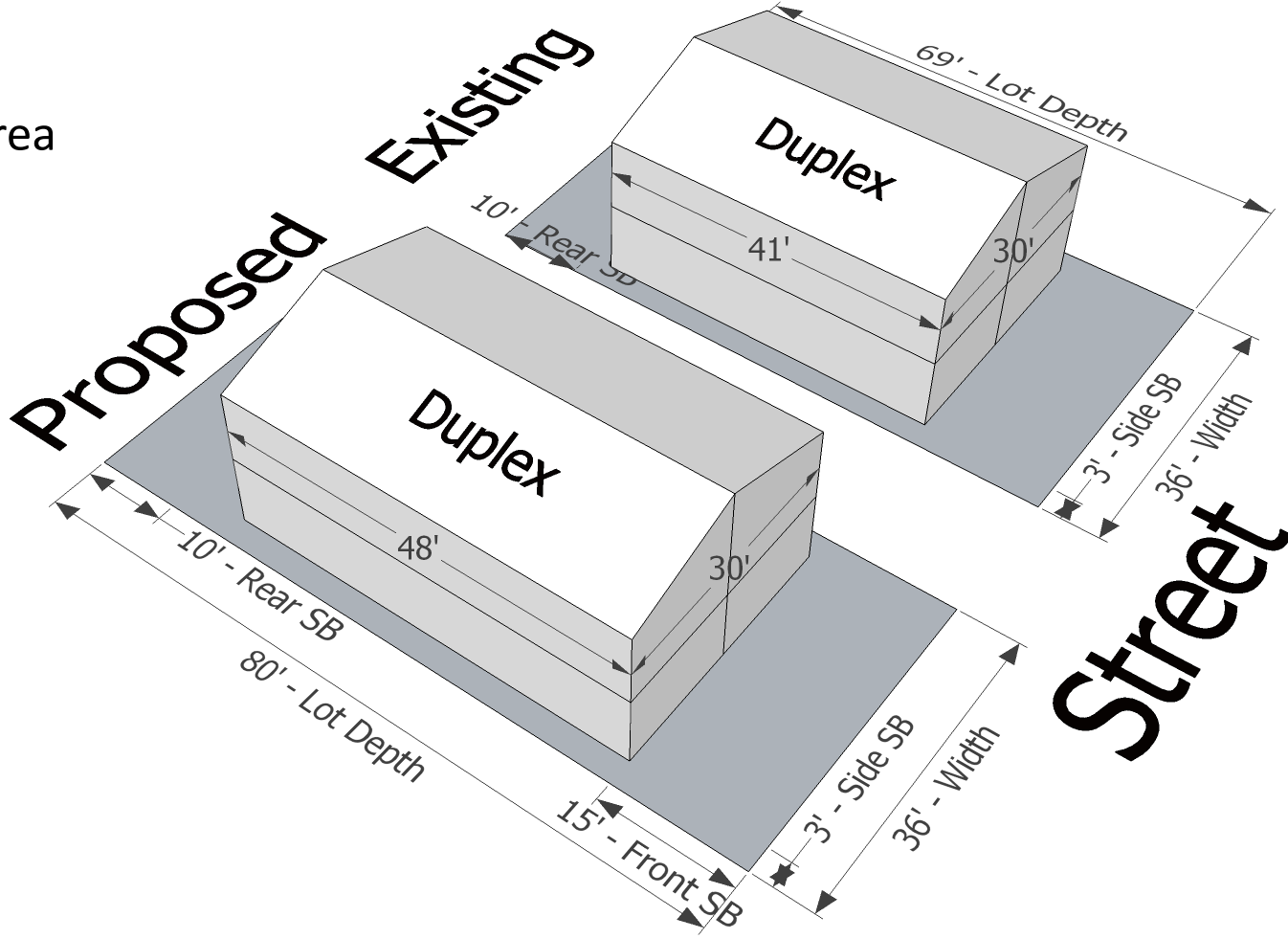

RMF – Single Family, Attached (1-story) Alley Parking Example

Existing:
2500 sq. ft. min. lot area
25' min. lot width

Proposed:
1600 sq. ft. min. lot area
16' min. lot width

Similarities:
15' front setback
10' rear setback
6' side setback
No FAR limit

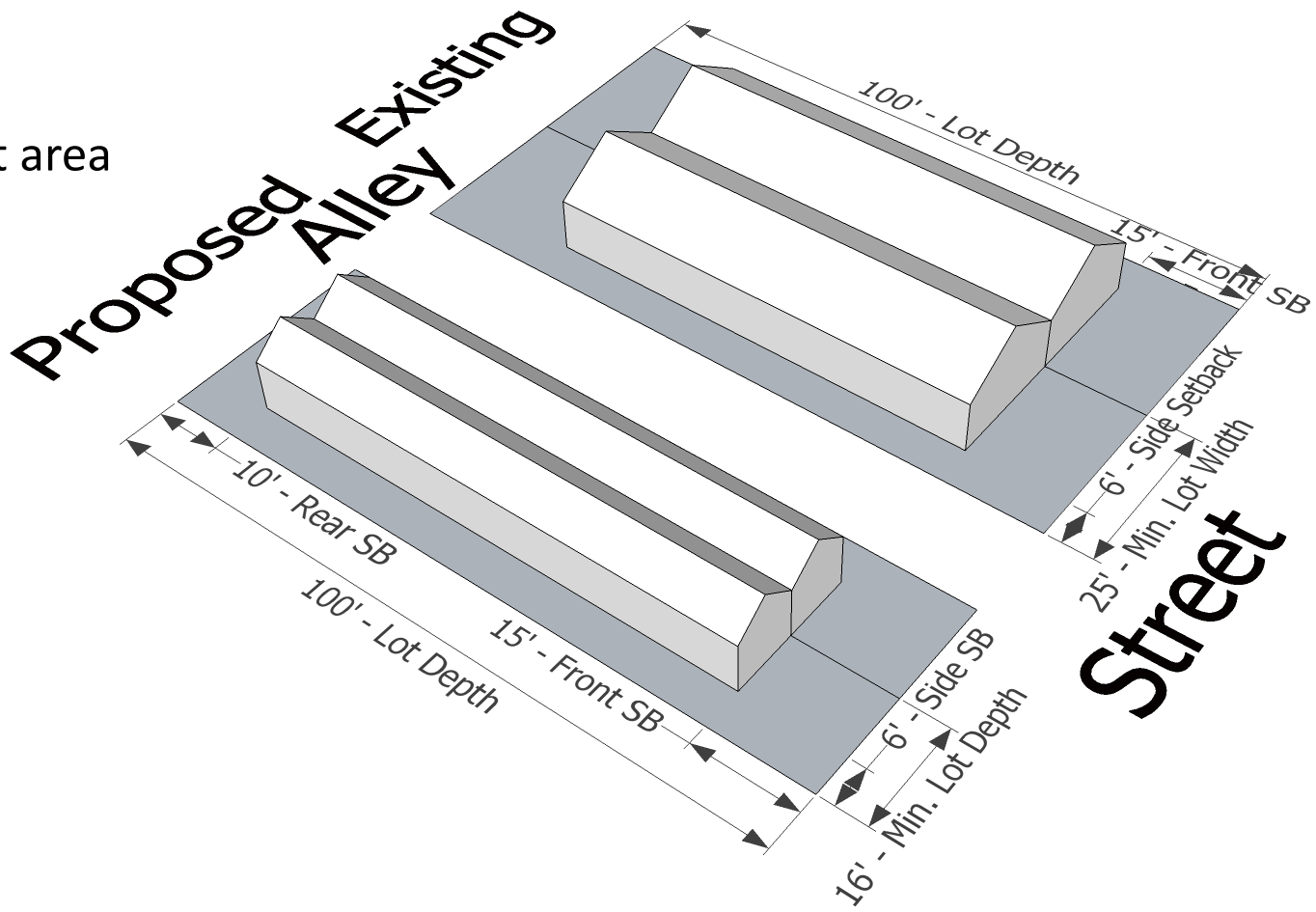

RMF – Single Family, Attached (2-story)

Alley Parking Example

Existing:

2500 sq. ft. min. lot area

25' min. lot width

Proposed:

1600 sq. ft. min. lot area

16' min. lot width

Similarities:

15' front setback

10' rear setback

6' side setback

No FAR limit

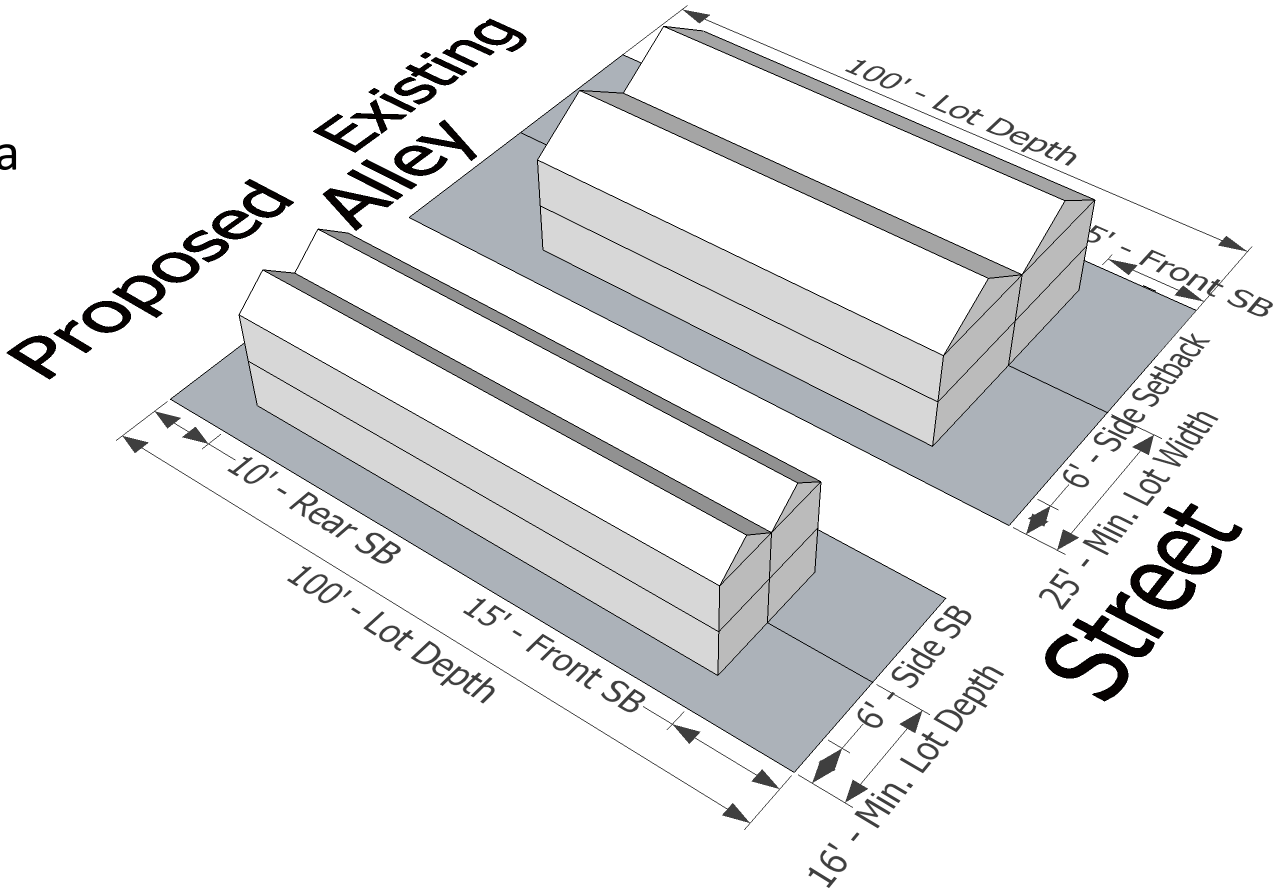

RSF-C – Single Family, Detached (2-story)

Accessory Structure Example

RSF:

- 4350 sq. ft. min. lot area
- 40' min. lot width
- 5' side setback
- 25' rear setback

RSF-C:

- 3000 sq. ft. min. lot area
- 36' min. lot width
- 3' side setback
- 15' rear setback

Similarities:

- 15' front setback
- 0.5 FAR

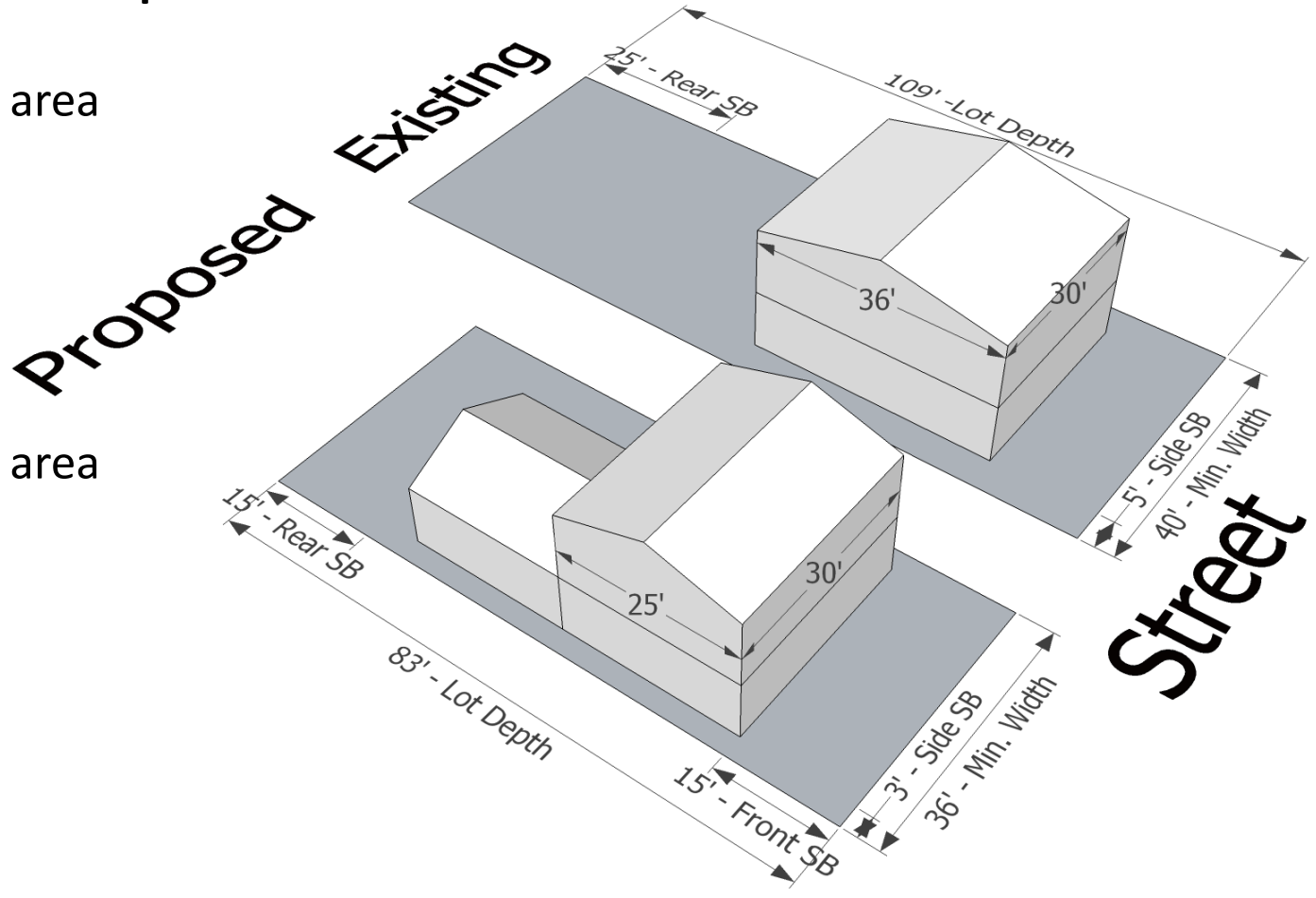

Attached accessory structures: 5' from rear property line (p/l), 20' from front p/l, same as primary structure on side

Detached accessory structures: 0 feet from rear p/l, 20' from front p/l, may be reduced to 0' from side w/side yard waiver

Maximum lot coverage for accessory structures: 15%